



Your Accessibility Partners

ES-125
Planning Guide



Company Intro

Company intro

Savaria Concord Lifts is now the second largest accessibility company in North America. Savaria was founded in 1979, and has acquired Concord Elevator Inc. in July 2005.

Savaria Concord Lifts' mission is to provide products that facilitate mobility of all people with special needs, contributing to their well-being and quality of life.

Savaria Concord Lifts stands behind all its products, which meet safety standard requirements for various countries around the world. With the help of our network of over 600 distributors, our products are distributed in North America, South America, Europe, and Australia. In addition, we now have an exclusive dealer and partnership in Dubai, United Arab Emirates.

We manufactured over 4400 lifts and stairlifts in 2006 at the facility of Savaria . Our products contribute to a higher quality of life in homes and businesses by improving access.

It is a pleasure to introduce you to Savaria's complete line of accessibility products.

- V-1504 Vertical Platform Lift
- P.A.L Vertical Platform Lift
- Telecab Vanishing Residential Elevator
- Multilift Residential Acme Screw Drive Vertical Platform Lift
- ES-125 Stair Platform Lift
- Step-Saver™ Stairway Chairlift
- B.07 Stairway Chairlift (battery, 110VAC power, or commercial)
- Stairfriend™ Curved Stairway Chairlift
- Orion Lu/La Commercial Elevator
- Prolift Residential or Commercial Elevator
- Ultimo Residential or Commercial Elevator

We thank you for your support and interest in our company.

Cordially,



Marcel Bourassa, B.A.A.
President



Robert Berthiaume, P. Eng.
Executive V.P.

Definition of an Inclined Platform Lift

Platform lifts are designed to provide easy access for the physically challenged from one landing to another. The innovative design of Savaria lifts can meet any challenges and can be installed in homes, schools, churches, municipal buildings, nursing homes, restaurants...

The ES-125 stair wheel chair platform lift is designed for residential and commercial use. Its compact folding platform leaves the stairway virtually unobstructed when not in use. It can be used both indoors and outdoors.

According to **A.S.M.E.** (American Society of Mechanical Engineers) safety standards, an inclined platform lift is a powered hoisting and lowering mechanism designed to transport a mobility-impaired person on a guided platform that travel on an incline.

C.S.A. (Canadian Standard Association) safety standards define a stair platform lift as a nonportable, permanently installed elevating device for transporting persons with physical disabilities between two or more levels by means of a guided carriage moving substantially in the direction of a flight of stairs or a ramp, equipped with a carriage in the form of a platform.

Please contact your local Savaria Concord Authorized dealer for further details.

Table of contents

Definition of an Inclined Platform Lift.....	2
Table of Contents.....	4
1- Technical Analysis of an ES-125	5
Specifications	5
2- Anatomy of the Lift.....	6
Wall Installation.....	7
4- Drive System	8
4.1- ES-125P (aircraft cable and drum)	8
Anatomy of the Lift	8
4.2- ES-125Plus (chain drive with top landing cabinet)	9
5- Annex.....	10
5.1- Dimensions	10
5.2- Drawings.....	11
5.2.1 ES-125P	11
5.2.2- ES-125Plus	13
6- Architect Specifications.....	14
ES-125P	14
ES-125PLUS	18

1- Technical Analysis of an ES-125

Specifications

Platform Dimensions	Type I: 27.50" x 36" (700 x 914 mm) Type II: 28.50" x 44" (724 x 1,118 mm) Type III: 30" x 48" (762 x 1,219 mm) Type IV: 30" x 44" (762 x 1,118 mm) Platform can be folded manually or with the help of an optional power-fold platform. Car folds within 11 in.(279mm) of wall(residential)
Rail	Heavy gauge steel composite rail
Access Ramps	Two positive action automatic access ramps for straight or 90° entry
Motor Assembly	110 VAC, ½ hp (373 W), 1,750 rpm / gear reducer: 50:1
Type of Drive Unit	Standard system: Steel aircraft cable 3/16" (5 mm) with breaking load of 4,200 lb (1,950 kg), deviator pulley, controller and winding drum in a machine room. Plus system: Roller chain #50 and steel aircraft cable with breaking load of 6,100 lb (2,767 kg). The electric motor gear reducer and controller are self enclosed at the top landing in a drive cabinet. No machine room required.
Controller	Meets CSA and ETL standards - 24 VAC operating controls
Power Supply	110 VAC, 1Ph, 60Hz, 15 amp
Rated Speed	14.0 ft / min. (0.071 m / s)(approx.)
Capacity	One person in a wheelchair
Rated Load	450 lb (204 kg)
Operating Controls*	Continuous pressure directional buttons are installed on the platform with a key switch for increased safety. (*)
Call Stations	Keyed call/send controls on platform and at each landing (wall mounted)
Finish	Electrostatic powder coat paint on all steel surfaces and ABS vacuum-formed plastics.
Safety Features	Automatic dual access ramps Underpan sensors Obstruction sensors on access ramps Mechanical emergency brake Slack cable switch Non-skid surface on platform and ramps Keyed continuous pressure controls Upper / lower limit switches 2 grab rails on car

*Consult local codes and regulations

2- Anatomy of the Lift

Here is the general layout of the ES -125

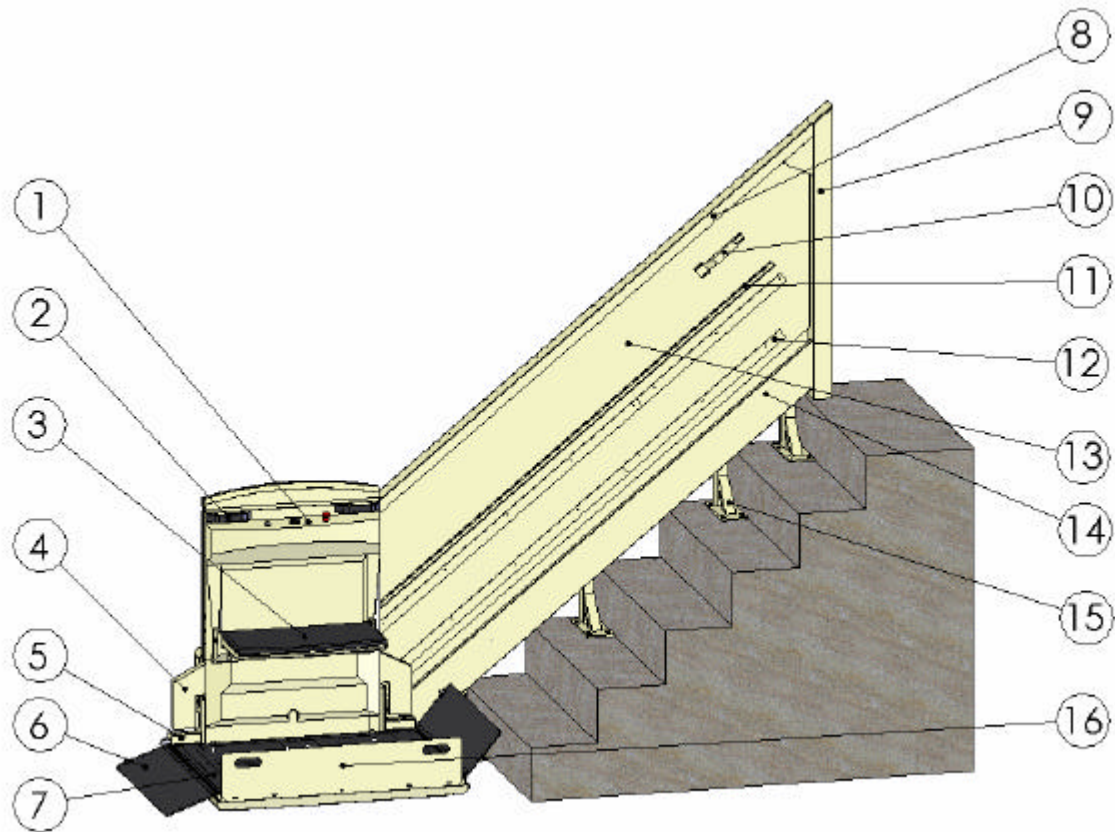

Number	Description	Number	Description
1	Control operation panel (C.O.P.)	9	Cable guard
2	Hand rails	10	Limit cams
3	Foldable seat with safety belt (optional)	11	Flap rail (for Plus model a chain guard rail appears under the flap rail)
4	Shear protector (optional)	12	Rolling strips
5	Safety edges limit switch	13	Plastic laminated panel
6	Automatic access ramp	14	Counter weight traveling cable rail
7	Non skid platform	15	Self support post (optional)
8	Guide rail	16	Fixed side guard panel

3- Site construction details

Wall Installation

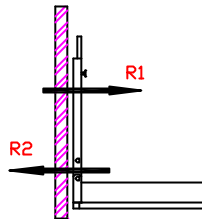

REACTIONS ACTING ON SUPPORT WALL
 $R1 = R2 = 670.0 \text{ Lb } (3.0 \text{ kN})$

Pull-out force on support wall is approximately 670 lb (3 kN). Adequate structural support must be provided at top landing bottom landing and throughout the supporting wall along the stairs.

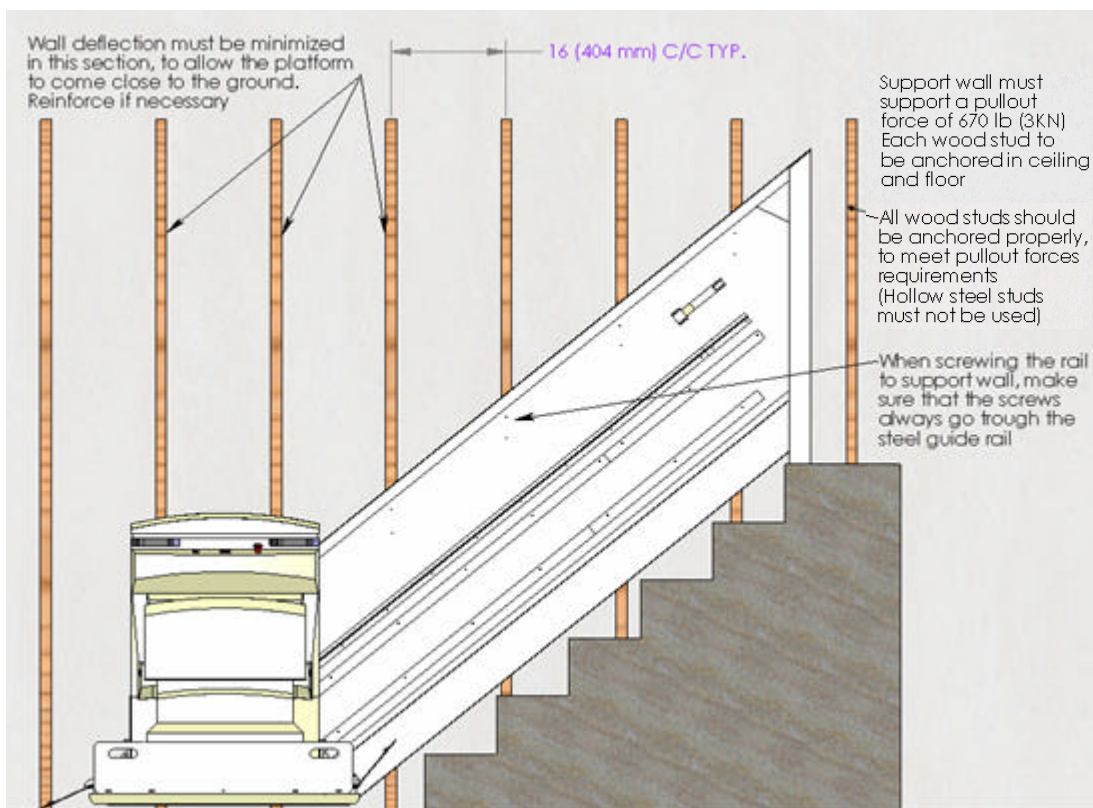

4- Drive System

The ES-125 is offered with 2 types of drive system

4.1- ES-125P (aircraft cable and drum)

- The ES-125P is an aircraft cable and drum assembly and requires a machine room normally located beneath the stairs.

Anatomy of the Lift

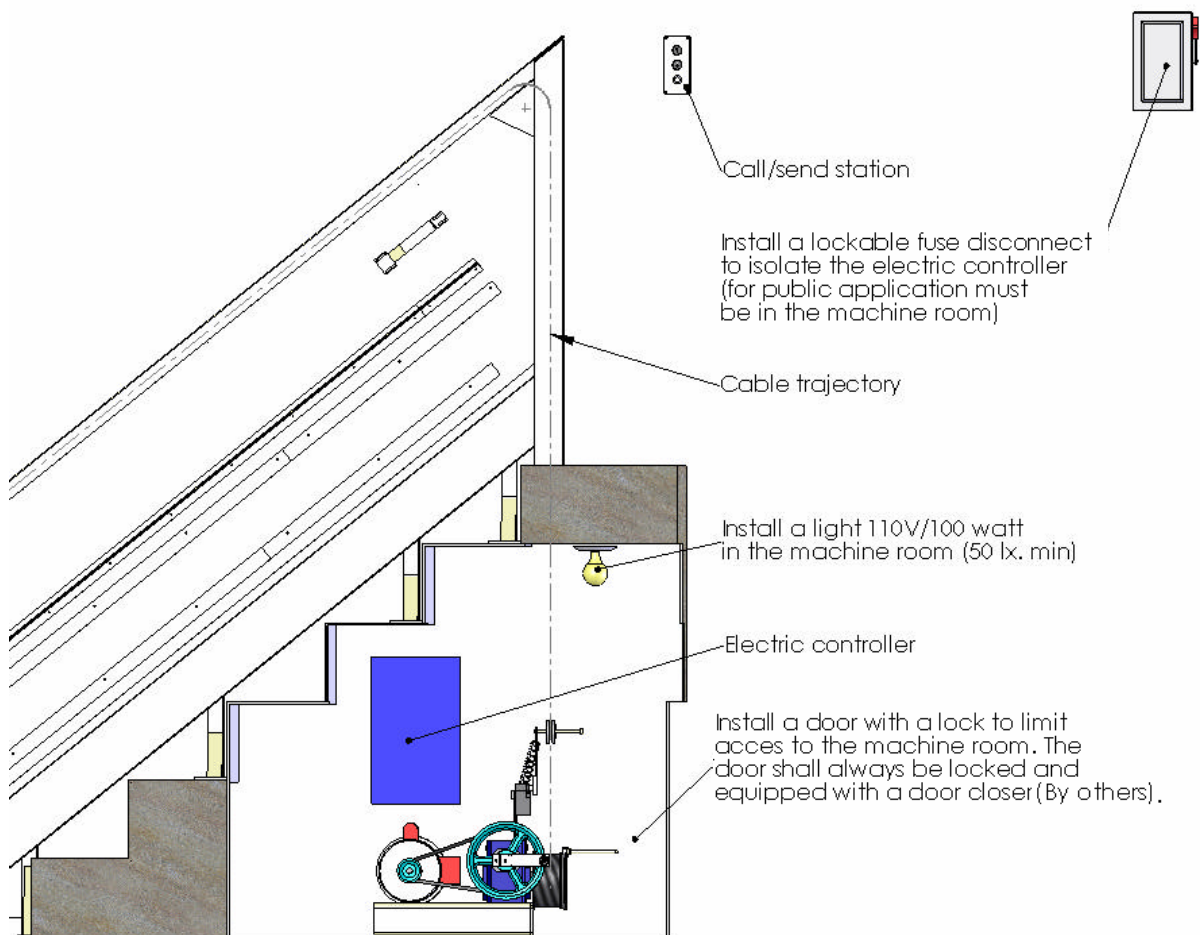

4.2- ES-125Plus (chain drive with top landing cabinet)

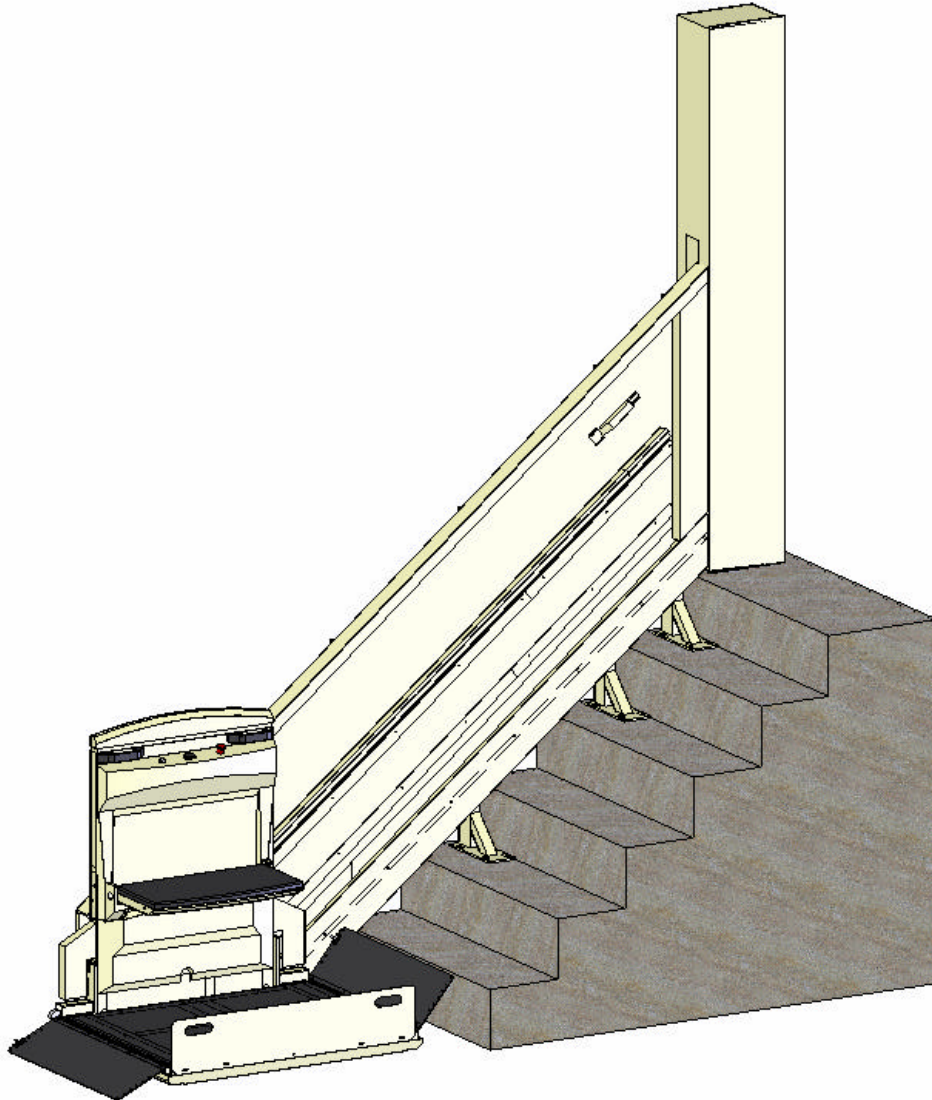

- The ES-125Plus is a chain and sprocket system and does not require a machine room. The motor and controller are located in a top landing cabinet.

5- Annex

5.1- Dimensions

Plan View

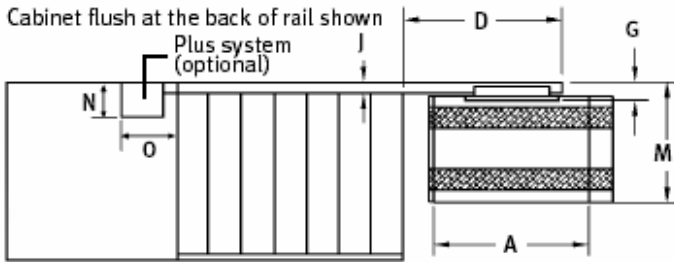

Measurements are in inches (mm) •
 These drawings should be used for reference purposes only •
 Measurements and features may change without notice •

Elevation View

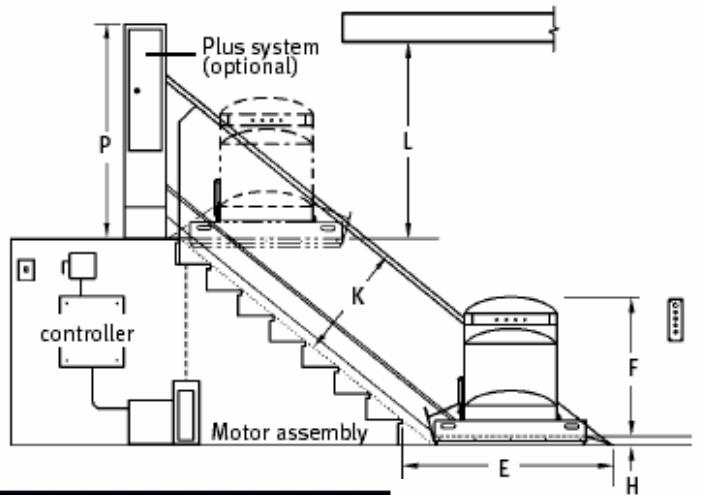

Platform Dimensions						
	TYPE I		TYPE II or IV		TYPE III (A.D.A.)	
	inches	mm	inches	mm	inches	mm
	27.50 X 36	(700 X 914)	28.50 X 44	(724 X 1,118)	30 X 48	(762 X 1,219)
A	36.00	(914)	44.00	(1,118)	48.00	(1,219)
B	27.50	(700)	28.50	(724)	30.00	(762)
C	13.00	(330)	13.00	(330)	13.00	(330)
D	41.00	(1,042)	44.00	(1,118)	45.00	(1,143)
E	55.00	(1,397)	65.00	(1,651)	70.00	(1,778)
	Side entry (90°) (May vary depending on stair slope)					
	Subtract 5 (127)		Subtract 8 (203)		Subtract 8 (203)	
F	38.00	(965)	38.00	(965)	38.00	(965)
G	5.25	(133)	5.25	(133)	5.25	(133)
H	2.00	(51)	2.50	(64)	2.50	(64)
J	2.75	(70)	3.00	(76)	3.00	(76)
	Add 3/8 (9) for bolt thickness					
K	31.125	(791)	33.625	(854)	34.625	(879)
L	59.00	(1,500)	59.00	(1,500)	59.00	(1,500)
	Minimum required by Code					
M	34.00	(864)	35.00 (1)	(889)	36.50	(927)
	Side entry (90°) - Add 6 (152)					
N	8" (203)					
O	17.50" (445) for all cabinets					
P	72.50" (1,842) min.					

Platforms can be custom-built if necessary.
 Measurements are for a typical 35° staircase.
 For more information, please contact our engineering department.

(1) 36.50 for type IV

GENERAL SPECIFICATIONS:

GENERAL SPECIFICATIONS:

- INSTALL A LOOKABLE FUSE DISCONNECT IN THE MACHINE ROOM TO ISOLATE THE ELECTRIC CONTROLLER FROM THE MAIN SUPPLY (120V/208V/240V/277V/347V/480V) BY OTHERS
- INSTALL A LIGHT 110V/100 WATT IN THE MACHINE ROOM (50 Lx MIN.)
- ELECTRIC CONTROLLER FOR THE PLATFORM CSA-UR 107843-1
- INSTALL A DOOR WITH A LOCK TO LIMIT ACCESS TO THE MACHINE ROOM THE DOOR MUST ALWAYS BE LOCKED AND EQUIPPED WITH A DOOR CLOSER BY OTHERS
- MOTOR BRACKET ANCHORAGE: 6X SLEEVE ANCHORS 1/2"-3/4" FOR CONCRETE FLOOR MIN. HOLE DSP-RI: 1.623" 2000 PSI CONCRETE FLOOR MIN. REQ'D SITE CONDITIONS TO DETERMINE EXACT MOTOR ASSEMBLY LOCATION DEFLECTING PALLEY ANCHORAGE CONCRETE: 4 X SLEEVE ANCHOR 3/8"-5" WOODS: 4 THROUGH BOLTS 1/4" DIA. GRADE 5 FORCE TRANSFERRED ON ANCHOR POINT= 800 LBS ADEQUATE STRUCTURAL SUPPORT TO BE PROVIDED
- THIS EQUIPMENT MUST BE INSTALLED IN COMPLIANCE WITH THE CSA B355-94 CODE BY QUALIFIED TECHNICIANS ONLY.

AT ALL TIMES CLEARANCE OVER PLATFORM MUST BE AT LEAST 1.5m IN ORDER TO COMPLY WITH CSA B355.

FOR APPROVAL

APPROVED BY :

DATE :

AT ALL TIMES CLEARANCE OVER PLATFORM MUST BE AT LEAST 1.5m IN ORDER TO COMPLY WITH CSA B355.

UPPER CALL STATION
LOWER CALL SEND

35 1/8
28 3/4 P-F
44 P-F
44
3

FOR APPROVAL
APPROVED BY :

DATE :

AT ALL TIMES CLEARANCE OVER PLATFORM MUST BE AT LEAST 1.5m IN ORDER TO COMPLY WITH CSA B355.

GUIDE RAIL STEEL 3/16" THICK ANCHORING TO SUPPORT WALL: PROPER ANCHORS FOR HOLLOW BLOCK BY INSTALLER MINIMUM OF 1 EVERY 20" THROUGH TOP METAL RAIL

93 TRAVEL
2 3/4
31.8
11 1/4
68
7
40
49

GALVANIZED AIRCRAFT CABLE ONE (1) 7 X 19 TYPE NOMINAL DIA. 3/16"

MOTOR
CONTROLLER

CAR STATION
UP/DOWN SWITCH
EMERGENCY KEY

LOWER & UPPER CALL STATIONS
EMERGENCY KEY
UP BUTTON
DOWN BUTTON

DIMENSIONS ARE IN INCHES

STARWAY PLATFORM LIFT MODEL ES-125P

ACCESS TO PLATFORM IN LINE

ANGLE OF STAIRCASE: 31.3°

WIDTH OF STAIRCASE: 44"

HEIGHT OF STAIRWAY: 49"

HEIGHT OF STAIRWAY: 49"

NUMBER OF RISERS: 7

NUMBER OF RAIL SECTIONS: 1

OPTIONS: THREE POSITION SAFETY ARMS
POWERFOLD PLATFORM
AUDIO VISUAL ALARM
APPROVAL/PROPOSAL DRAWING

CUSTOMER: THE ACCESS STORE

PROJECT: WINNIPEG HARVEST

- RATED LOAD : 450 Lbs (204 kg)
- CAPACITY : ONE PERSON IN WHEELCHAIR
- RATED SPEED : 16 ft/min
- RIDER CAR : 1100 LB
- POWER SUPPLY : 110V/208V/240V/277V/347V/480V
- OPERATION : CONSTANT PRESSURE
- PLATFORM SIZE: 28 3/4" X 44"
- ELEVATING CLASS : UNENCLOSED STAIR PLATFORM LIFT
- FINISH COLOR STANDARD

PULL-OUT FORCE ON SUPPORT WALL IS APPROXIMATELY 100 LBS IN A HORIZONTAL DIRECTION. SHORT TO BE PROVIDED TO BE INSTALLED IN THE BOTTOM LANDING AND THROUGHOUT THE SUPPORTING WALL ALONG THE STAIRS.

MODEL: ES125P	QTE: 1	TOLERANCES SI NON SPECIFIES			
DEC. D3D	ANG. 0.150"				
ECHELLE No.	DESIGNE PAR: P. DANILAKIS	NO.	REVISIONS	DATE	
MATERIAUX: S/O	DATE: 07/16/09				
DESSIN NO: 8823P08	HEVY FEUILLE:				
SERVICES INDUSTRIELS SAVARIA INC.					
LIFT FOR HANDICAPPED					

5.2.2- ES-125Plus

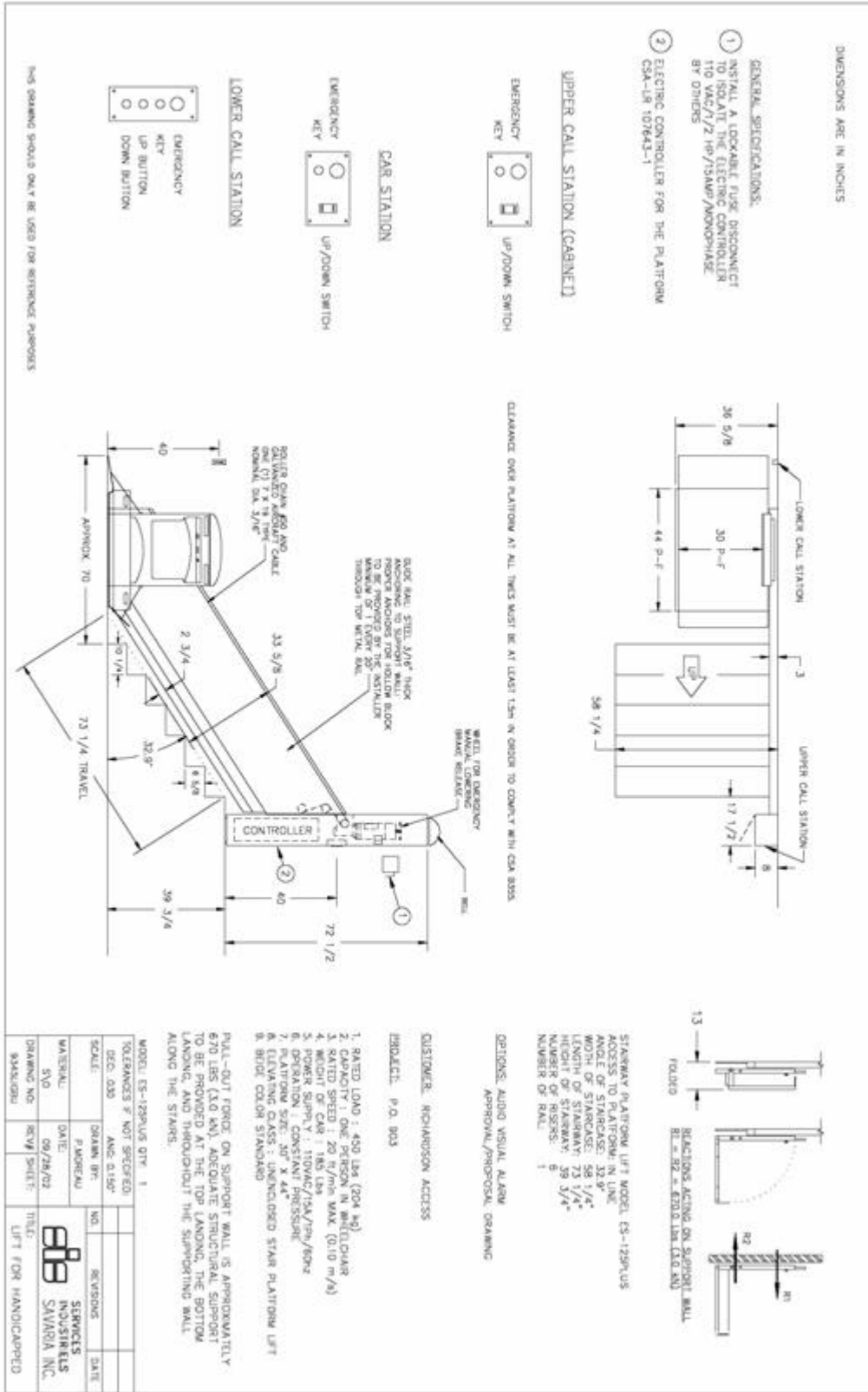

6- Architect Specifications

ES-125P

Section14420

Typical inclined platform lift specifications

Savaria model ES -125P (Aircraft cable and drum drive system)

1.0

GENERAL

RELATED DOCUMENTS :

Drawings and general provisions of the contract, including instructions to bidders, supplementary instructions to bidders, general conditions, and specification sections apply to work of this section.

1.1

DESCRIPTION

- A. The product described here is produced by Savaria Corporation Inc. It is an inclined platform lift with an aircraft cable and winding drum assembly located under the stairs. It is designed for indoor or outdoor (with optional package) applications.

Where singular reference is made to lifts or lift components, such reference shall apply to number of lifts or components required to complete installation. This specification provides a broad outline of required equipment and does not describe the details of design and construction. Lifts shall be erected, installed, adjusted, tested and placed in operation by lift system manufacturer, or manufacturer's authorized installer.

- B. Lifts shall be in accordance with ASME A18.1 and ADA compliant including local codes and regulations except where specified otherwise.

1.2

PREPARATORY WORK BY OTHERS

- A. The following preparatory work to receive the lifts specified in this section is part of the work by others. :
1. Permanent 120 VAC 20 amp single phase power to operate lift to be provided from lockable fused/cartridge type disconnect switch. Refer to drawings for permanent power specifications and location of disconnects. Temporary power may be provided to expedite installation of lift.
 2. Provide a plumb and square support wall with smooth interior surfaces. If support wall is not available, provide tread anchors for support posts.
 3. Provide staircase per lift manufacturer's shop drawings.

1.3

QUALITY ASSURANCE

- A. **SUBCONTRACTOR QUALIFICATIONS:**
1. Execute work of this section only by a company that has adequate product liability insurance.
 2. Skilled tradesmen must be employees of the installing contractor approved by the lift manufacturer, with demonstrated ability to perform the work on a timely basis.
- B. **REQUIREMENTS OF REGULATORY AGENCIES:**
1. Fabricate and install work in compliance with applicable jurisdictional authorities.

2. File shop drawings and submissions with local authorities as the information is made available. Company pre-inspection and jurisdictional authority inspections and permits are to be made on timely basis as required.
3. Submit certification that platform lift system complies with current ADA requirements.

1.4 SUBMITTALS

- A. SHOP DRAWINGS— the shop drawings shall show a complete layout of lift equipment detailing dimensions and clearances as required.
- B. Submit physical samples of all items requiring selection of color or finish.

1.5 WARRANTY

- A. The manufacturer shall provide at least a 30 months limited guarantee on parts.

2.0 PRODUCTS

2.1 PLATFORM LIFT

- A. Basics of specifications for Savaria Concord inclined wheelchair lift model ES125P with the following characteristics :
 - 1.Rated Load..... 450 lb (204 kg)
 - 2.Rated Speed.....14 f.p.m. (0.071 m/s)
 - 3.Platform size (ADA requirement).....30" x 48" (762 x 1,219 mm)
 - 4.Levels serviced.....2
 - 5.Car Access.....Front/Back or 90° exit
 - 6.Operations.....Constant Pressure
 - 7.Power Supply120V, 15 Amp, 1 Phase, 60 hz
 - 8.Drive System.....Aircraft cable and winding drum
 - 9.Paint.....Powder coat finish
 - 10.Emergency Operation.....Manual lowering and raising
 - 11.Controller.....Electronic-free relay logic
 - 12.Safety Arms.....Three (3) folding positions: Up, Down, center or powered up/down
 - 13.Passenger Seat.....27.5" wide x 12" deep, foldable with seat belt
 - 14.Platform Action.....Motorized or manual folding system at top and bottom landings
 - 15.Motor assembly.....120VAC, ½ hp, 1,750 rpm / gear reducer: 50:1
 - 16.Color.....Almond beige

2.2 MECHANICAL PROVISIONS

- A. Platform type ES-125P: The unit shall have an aircraft cable and winding drum drive system located under the stairs for a clean and quiet installation at the top landing. Platform may have a motorized folding mechanism. This folding action shall be done from the call station adjacent to the occupied landing.
- B. Loading and unloading of safety ramps to be operated by a positive mechanical action when the car leaves the landing. The control of all power features are located in call stations so wheelchair users can be away from the stair until the platform is in loading position.
- C. The ramps are touch sensitive and shall stop the unit when encountering an obstruction on the stairs. The platform shall have a non- skid surface. Shaped to prevent accidental wheelchair roll-off. Sidewalls

functions as vandal resistant cover to protect platform control switches when in folded position. A fold-up ambulatory seat, complete with safety belt is to be provided on the platform for disabled who do not use a wheelchair.

2.3 PLATFORM CONTROLS

Key switch, emergency stop, constant pressure call/send controls and hand pendant control for attendant operation. Platform ramps on both sides and platform underside with obstruction sensitive cut off assure safety. An audio-visual alarm shall be provided.

2.4 CONTROLS AT EACH LANDING

Key switch, constant pressure platform call/send buttons and emergency stop switch. When using optional motorized platforms, constant pressure switches shall fold and unfold the platform.

2.5 CLEARANCE

- A. When folded, platform shall not protrude more than 13'' from inner wall or more than 36 ½'' from inner wall in use unfolded (based upon direct mount to attachment wall). ANSI specification B-29.2.

2.6 EMERGENCY OPERATION

- A. Hand wheel shall be provided for emergency operation during power failure.
B. Safety brake shall be included in the mechanism in case of drive system failure.
C. Slack cable switch that will stop the power in case of cable failure.

2.7 AIRCRAFT CABLE

- A. One (1) aircraft cable with no less of 3/16'' diameter, with breaking load of 4,200 lbs.

2.8 GUIDE RAILS AND BRACKETS

- A. Support rail to be steel, offset C-Channel. Rail to be directly mounted to solid walls or steel tower mounted to stair tread and stringer as shown on drawings.

2.9 PAINT COLOR

- A. To be selected by owner/architect from manufacturer's colors of powder coat finish. The standard color is almond beige.

2.10 SECURITY LOCKS

- A. Security lock, utilizing the operation key, may be provided. This lock to prevent unauthorized unfolding of standard platform.

2.11 MOTORISED SAFETY ARMS

- A. Where the retractable arm are power operated, control shall be by means of a continuous pressure device. The closing speed shall not exceed 1 ft/sec.
B. The arms shall be located above the perimeter of the platform floor at not less that 32 in.(813 mm) or greater that 38 in.(965mm). Gaps between the adjacent ends of arm sections shall not exceed 4 in. (102 mm) when the arms are in their guarding positions.
C. The arms shall be of smooth construction with all edges rounded. They shall not be permanently deformed when a force of 66 lbf (300N) is applied on any point along the length of the arms in any direction. They shall not be permanently deformed when a force of 225 lbf (1000N) is applied in the horizontal direction along the center line of the platform.

- D. The arms shall be provided in independent sections. At landings the retractable ramp and arm at the boarding end of the platform shall be operable only when the arm at the non-boarding end of the platform is in its locked guarding position.
- E. Each retractable arm shall be mechanically locked and monitored by an electric contact, which shall stop the movement of the platform within 2 in. (51mm) of travel away from any landing if the arm is not in its locked guarding position. Means shall be provided to manually unlock the retractable arms for emergency evacuation purposes. The unlocking mechanism shall not be readily accessible to the passenger.

3.0 ELECTRICAL PROVISIONS

- A. Power requirements to be 120 volt, single phase, 60 Hz, 15 amp. Confirm available power source to manufacturer at time of
- B. Wheelchair lift shall have a disconnect switch, as required by code, to completely cut power to the unit.
- C. 24 volt control wiring: Wheelchair lift contractor shall provide the routing of conduits on or through wall, floors, partitions along with the proper placement of junction boxes, call stations boxes and audio visual alert as necessary.
- D. Wheelchair lift contractor must provide manufacturer's product wiring diagrams, electrical schematics and electrical guidelines.
- E. All electric wire or power cables must be concealed in either rigid or flexible metal conduit.

4.0 EXECUTION

- A. EXAMINATION: All site dimensions shall be taken to ensure that tolerances and clearances have been maintained and meet local regulations.
- B. PREPARATION: Pre-inspect the construction and service requirements for work by others. These requirements will be included in drawings, diagrams, engineering data sheets and special instructions before the work commences.
- C. INSTALLATION:
 - 1. Install all the components of the lift system that are specified in this Section to be provided, and that are required by jurisdictional authorities to license the lift.
 - 2. Trained employees of the lift contractor shall perform all installation work of this section. Adjust lift for proper operation and clean unit thoroughly.
 - 3. Instruct Owner's Operation and Maintenance personnel in basic trouble-shooting and maintenance procedures.

END OF SECTION

ES-125PLUS

Section14420

Typical inclined platform lift specifications

Savaria model ES-125PLUS (Chain drive with top landing cabinet)

1.0 GENERAL

RELATED DOCUMENTS:

- A. Drawings and general provisions of the contract, including instructions to bidders, supplementary instructions to bidders, general conditions, and specification sections apply to work of this section.

1.1 DESCRIPTION

- B. The product described here is produced by Savaria Corporation Inc. It is an inclined platform lift with a roller chain drive system designed for indoor or outdoor (with optional package) applications. Where singular reference is made to lifts or lift components, such reference shall apply to number of lifts or components required to complete installation. This specification provides a broad outline of required equipment and does not describe the details of design and construction. Lifts shall be erected, installed, adjusted, tested and placed in operation by lift system manufacturer, or manufacturer's authorized installer.
- B. Lifts shall be in accordance with ASME A18.1 and ADA compliant including local codes and regulations except where specified otherwise.

1.2 PREPARATORY WORK BY OTHERS

- A. The following preparatory work to receive the lifts specified in this section is part of the work by others. :
1. Permanent 120 VAC 20 amp single-phase power to operate lift to be provided from lockable fused/cartridge type disconnect switch. Refer to drawings for permanent power specifications and location of disconnects. Temporary power may be provided to expedite installation of lift.
 2. Provide a plumb and square support wall with smooth interior surfaces. If support wall is not available, provide tread anchors for support posts.
 4. Provide staircase per lift manufacturer's shop drawings.

1.3 QUALITY ASSURANCE

- A. SUBCONTRACTOR QUALIFICATIONS
4. Execute work of this section only by a company that has adequate product liability insurance.
 2. Skilled tradesmen must be employees of the installing contractor approved by the lift manufacturer, with demonstrated ability to perform the work on a timely basis.
- B. REQUIREMENTS OF REGULATORY AGENCIES:
5. Fabricate and install work in compliance with applicable jurisdictional authorities.
 6. File shop drawings and submissions with local authorities as the information is made available. Company pre-inspection and jurisdictional authority inspections and permits are to be made on timely basis as required.
 7. Submit certification that platform lift system complies with current ADA requirements.

1.4 SUBMITTALS

- A. SHOP DRAWINGS — the shop drawings shall show a complete layout of lift equipment detailing dimensions and clearances as required.
- B. Submit physical samples of all items requiring selection of color or finish.

1.5 WARRANTY

- A. The manufacturer shall provide at least a 30 months limited warranty on parts.

2.0 PRODUCTS

2.1 PLATFORM LIFT

- A. Basics of specifications for Savaria inclined wheelchair lift model ES-125PLUS with the following characteristics:

- 1. Rated Load.....450 lb (204 kg)
- 2. Rated Speed..... 14 f.p.m. (0.071 m/s)
- 3. Platform size (ADA requirement).....30" x 48" (762 x 1,219 mm)
- 4. Levels serviced.....2
- 5. Car Access.....Front/Back or 90° exit
- 6. Operations.....Constant Pressure
- 7. Power Supply..... 120V, 15 Amp, 1 Phase, 60 hz
- 8. Drive System.....Roller chain # 50
- 9. Paint.....Powder coat finish
- 10. Emergency Operation..... Manual lowering and raising
- 11. Controller.....Electronic-free relay logic
- 12. Safety Arms.....Three (3) folding positions: Up, Down, center or powered up/down
- 13. Passenger Seat.....27.5" wide x 12" deep, foldable with seat belt.
- 14. Platform Action.....Motorized or manual folding system at top and bottom landings.
- 15. Motor assembly..... 120VAC, ½ hp, 1,750 rpm / gear reducer: 50:1
- 16. Color.....Almond beige

2.12 MECHANICAL PROVISIONS

- A. Platform type ES-125PLUS : The unit shall have a roller-chain drive system, enclosed in a drive cabinet located at the upper landing. Platform may have a motorized folding mechanism. This folding action shall be done from the call station adjacent to the occupied landing.
- B. Loading and unloading of safety ramps to be operated by a positive mechanical action when the car leaves the landing. The control of all power features are located in call stations so wheelchair users can be away from the stair until the platform is in loading position.
- C. The ramps are touch sensitive and shall stop the unit when encountering an obstruction on the stairs. The platform shall have a non-skid surface. Shaped to prevent accidental wheelchair roll-off. Sidewalls functions as vandal resistant cover to protect platform control switches when in folded position. A fold-up ambulatory seat, complete with safety belt is to be provided on the platform for disabled who do not use a wheelchair.

2.13 PLATFORM CONTROLS

Key switch, emergency stop, constant pressure call/send controls and hand pendant control for attendant operation. Platform ramps on both sides and platform underside with obstruction sensitive cut off assure safety. An audio-visual alarm shall be provided.

2.14 CONTROLS AT EACH LANDING

Key switch, constant pressure platform call/send buttons and emergency stop switch. When using optional

motorized plat forms, constant pressure switches shall fold and unfold the platform.

2.15 CLEARANCE

A. When folded, platform shall not protrude more than 13'' from inner wall or more than 36 ½'' from inner wall in use unfolded (based upon direct mount to attachment wall). ANSI specification B-29.2.

B. EMERGENCY OPERATION

- D. Hand wheel shall be provided for emergency operation during power failure.
- E. Safety brake shall be included in the mechanism in case of drive system failure.
- F. Slack cable switch that will stop the power in case of cable failure.

2.16 AIRCRAFT CABLE

B. One (1) aircraft cable with no less of 3/16'' diameter, with breaking load of 4,200 lbs.

2.17 GUIDE RAILS AND BRACKETS

B. Support rail to be steel, offset C-Channel. Rail to be directly mounted to solid walls or steel tower mounted to stair tread and stringer as shown on drawings.

2.18 PAINT COLOR

A. To be selected by owner/architect from manufacturer's colors of powder coat finish. The standard color is almond beige.

2.19 SECURITY LOCKS

A. Security lock, utilizing the operation key, may be provided. This lock is to prevent unauthorized unfolding of standard platform.

2.20 MOTORIZED SAFETY ARMS

A. Where the retractable arm is power operated, control shall be by means of a continuous pressure device. The closing speed shall not exceed 1 ft/sec.

B. The arms shall be located above the perimeter of the platform floor at not less that 32 in.(813 mm) or greater that 38 in.(965mm). Gaps between the adjacent ends of arm sections shall not exceed 4 in. (102 mm) when the arms are in their guarding positions.

C. The arms shall be of smooth construction with all edges rounded. They shall not be permanently deformed when a force of 66 lb (300N) is applied on any point along the length of the arms in any direction. They shall not be permanently deformed when a force of 225 lb (1000N) is applied in the horizontal direction along the centerline of the platform.

D. The arms shall be provided in independent sections. At landings the retractable ramp and arm at the boarding end of the platform shall be operable only when the arm at the non-boarding end of the platform is in its locked guarding position.

E. Each retractable arm shall be mechanically locked and monitored by an electric contact, which shall stop the movement of the platform within 2 in. (51mm) of travel away from any landing if the arm is not in its locked guarding position. Means shall be provided to manually unlock the retractable arms for emergency evacuation purposes. The unlocking mechanism shall not be readily accessible to the passenger.

3.0 ELECTRICAL PROVISIONS

A. Power requirements to be 120 volt, single phase, 60 Hz, 15 amp. Confirm available power source to manufacturer at time of

B. Wheelchair lift shall have a disconnect switch, as required by code, to completely cut power to the unit.

- C. 24 volt control wiring: Wheelchair lift contractor shall provide the routing of conduits on or through wall, floors, and partitions along with the proper placement of junction boxes, call stations boxes and audio visual alert as necessary.
- D. Wheelchair lift contractor must provide manufacturer's product wiring diagrams, electrical schematics and electrical guidelines.
- E. All electric wire or power cables must be concealed in either rigid or flexible metal conduit.

4.0 EXECUTION

- A. EXAMINATION: All site dimensions shall be taken to ensure that tolerances and clearances have been maintained and meet local regulations.
- B. PREPARATION: Pre-inspect the construction and service requirements for work by others. These requirements will be included in drawings, diagrams, engineering data sheets and special instructions before the work commences.
- C. INSTALLATION:
 - 1. Install all the components of the lift system that are specified in this Section to be provided, and that are required by jurisdictional authorities to license the lift.
 - 2. Trained employees of the lift contractor shall perform all installation work of this section. Adjust lift for proper operation and clean unit thoroughly.
 - 3. Instruct Owner's Operation and Maintenance personnel in basic trouble-shooting and maintenance procedures.

END OF SECTION